

ITEM	PART NUMBER	REV	DESCRIPTION	QTY
1	00027-001		TABLE	6
2	00027-002		BENCH	12
3	00027-003		FRAMING	1

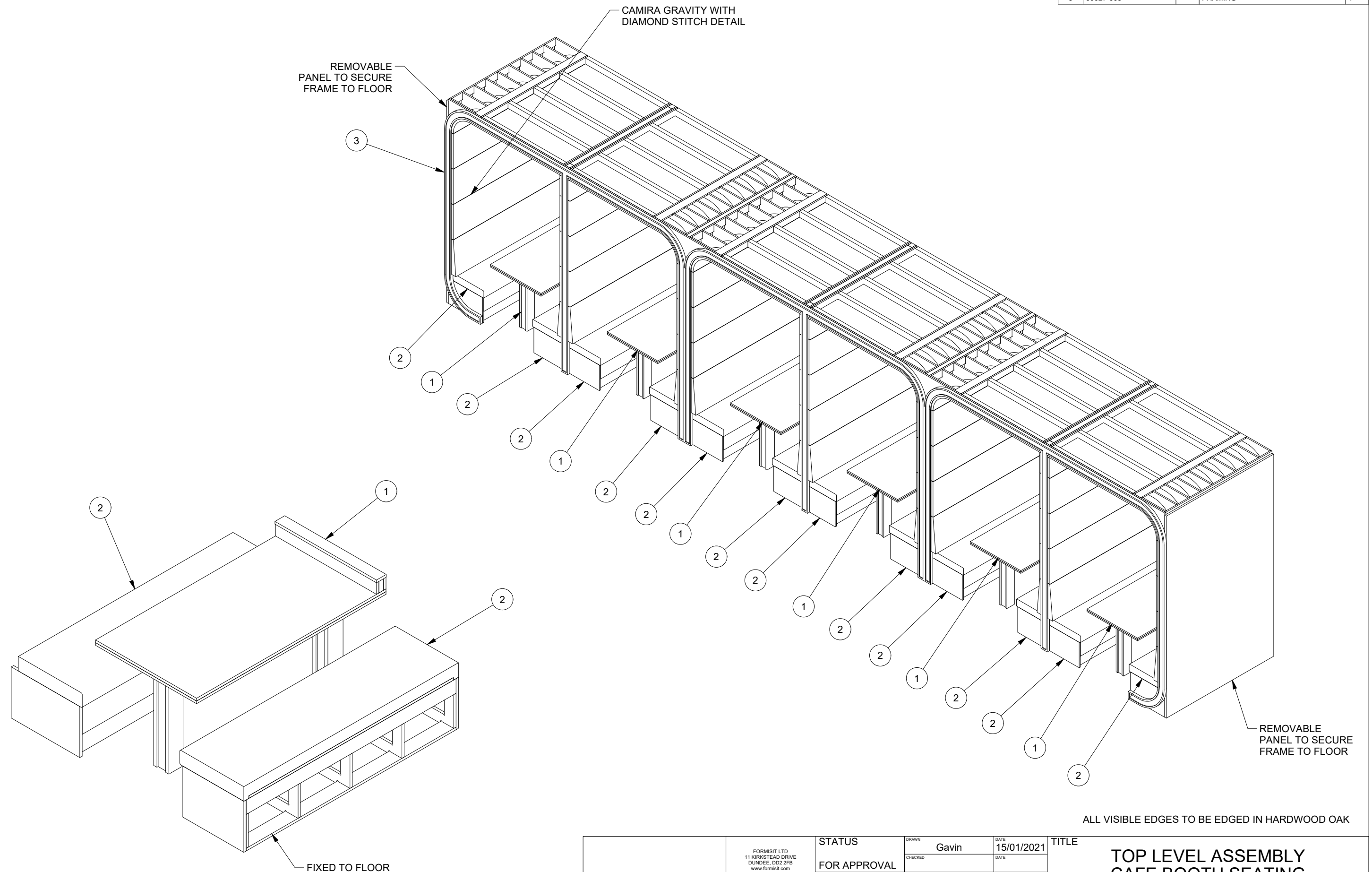

ALL VISIBLE EDGES TO BE EDGED IN HARDWOOD OAK

<b>FORMISIT</b>	<small>FORMISIT LTD 11 KIRKSTEAD DRIVE DUNDEE, DD2 2FB www.formisit.com info@formisit.com</small>	<b>STATUS</b> FOR APPROVAL <small>DOCUMENT TYPE</small>	<small>DRAWN</small> Gavin <small>CHECKED</small> <small>APPROVED</small>	<small>DATE</small> 15/01/2021 <small>DATE</small> <small>DATE</small>	<b>TITLE</b> TOP LEVEL ASSEMBLY CAFE BOOTH SEATING	
	<small>THIS DOCUMENT IS CONFIDENTIAL AND IS SUPPLIED ON THE EXPRESS CONDITION THAT IT SHALL NOT BE COPIED, LENT, OR DISCLOSED TO ANY OTHER PERSON OR USED FOR ANY OTHER PURPOSE WITHOUT THE WRITTEN CONSENT OF FORMISIT LTD.</small>		<small>DIMENSIONS ARE IN mm</small> <b>DO NOT SCALE</b>		<small>DWG. No.</small> 00027-000	<small>SHEET</small> 1 OF 2 <small>REV</small>
	<small>COPYRIGHT RESERVED</small>		<b>BS 8888</b>		<small>THIRD ANGLE PROJECTION</small>	<small>MATERIAL:</small> EST. MASS: 6517.48 kg

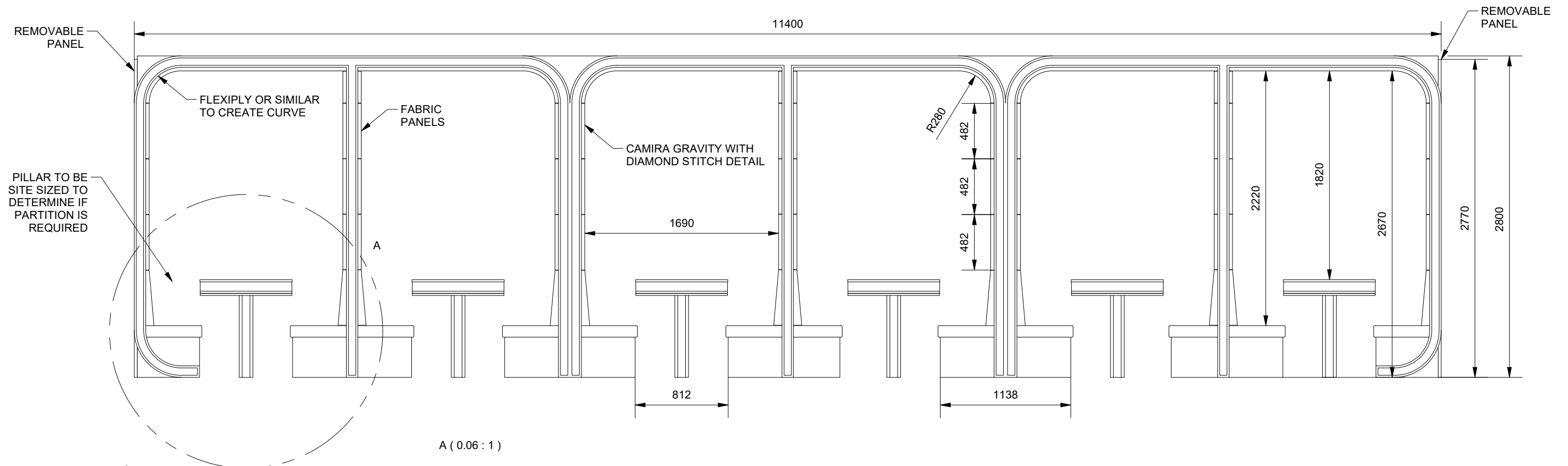
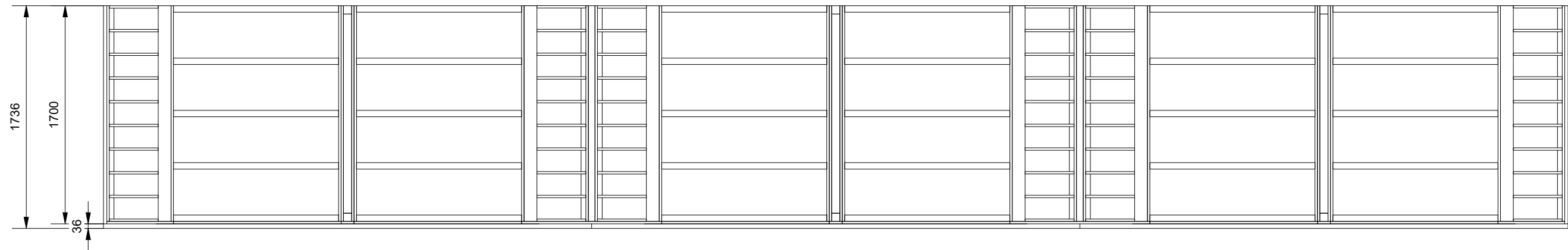

A (0.06 : 1)

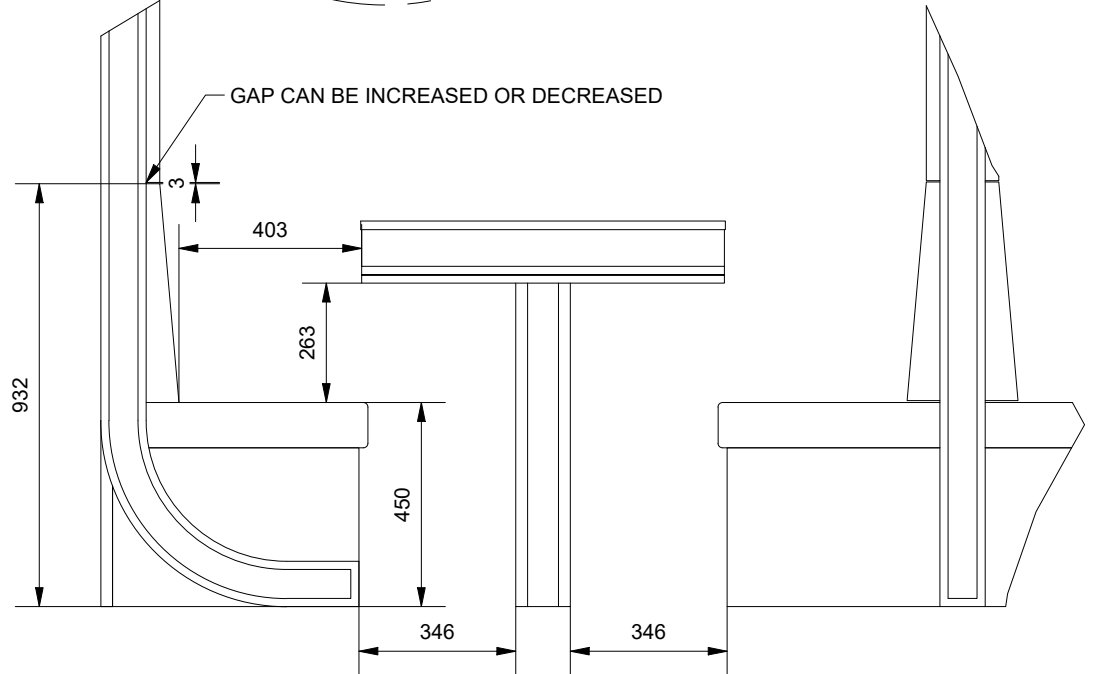

<b>FORMISIT</b>	<small>FORMISIT LTD 11 KIRKSTEAD DRIVE DUNDEE, DD2 2FB www.formisit.com info@formisit.com</small>	<b>STATUS</b> FOR APPROVAL <small>DOCUMENT TYPE</small>	<small>DRAWN</small> Gavin <small>CHECKED</small> <small>APPROVED</small>	<small>DATE</small> 15/01/2021 <small>DATE</small> <small>DATE</small>	<b>TITLE</b> TOP LEVEL ASSEMBLY CAFE BOOTH SEATING	
	<small>THIS DOCUMENT IS CONFIDENTIAL AND IS SUPPLIED ON THE EXPRESS CONDITION THAT IT SHALL NOT BE COPIED, LENT, OR DISCLOSED TO ANY OTHER PERSON OR USED FOR ANY OTHER PURPOSE WITHOUT THE WRITTEN CONSENT OF FORMISIT LTD.</small>			<small>DIMENSIONS ARE IN mm</small> <b>DO NOT SCALE</b>		<small>DWG. No.</small> 00027-000
	<small>COPYRIGHT RESERVED</small>			<b>BS 8888</b>		<small>MATERIAL:</small> EST. MASS: 6517.48 kg
					<small>SHEET</small> 2 OF 2 <small>SCALE:</small> 1 : 35 <small>SHEET:</small> A3	<small>REV</small>

ITEM	PART NUMBER	DESCRIPTION	MATERIAL	QTY
1	00027-001-0100-01	19mm OAK LAMINATE TOP	OAK VENEER MDF	1
2	00027-001-0300-01	18mm MDF (BOTTOM TO BE LAMINATED IN OAK OR WHITE)	OAK VENEER MDF	1
3	00027-001-0101-01	BOX END CAPS	OAK VENEER MDF	2
4	00027-001-0102-01	BOX FRONT/REAR PANEL	OAK VENEER MDF	2
5	00027-001-0103-01	BOX TOP	OAK VENEER MDF	1
6	00027-001-0202-02	LEG END PANEL	OAK VENEER MDF	4
7	00027-001-0104-02	LEG FRONT PANEL	OAK VENEER MDF	4
8	00027-001-0301-01	18mm INNER SUPPORTS	MDF	8

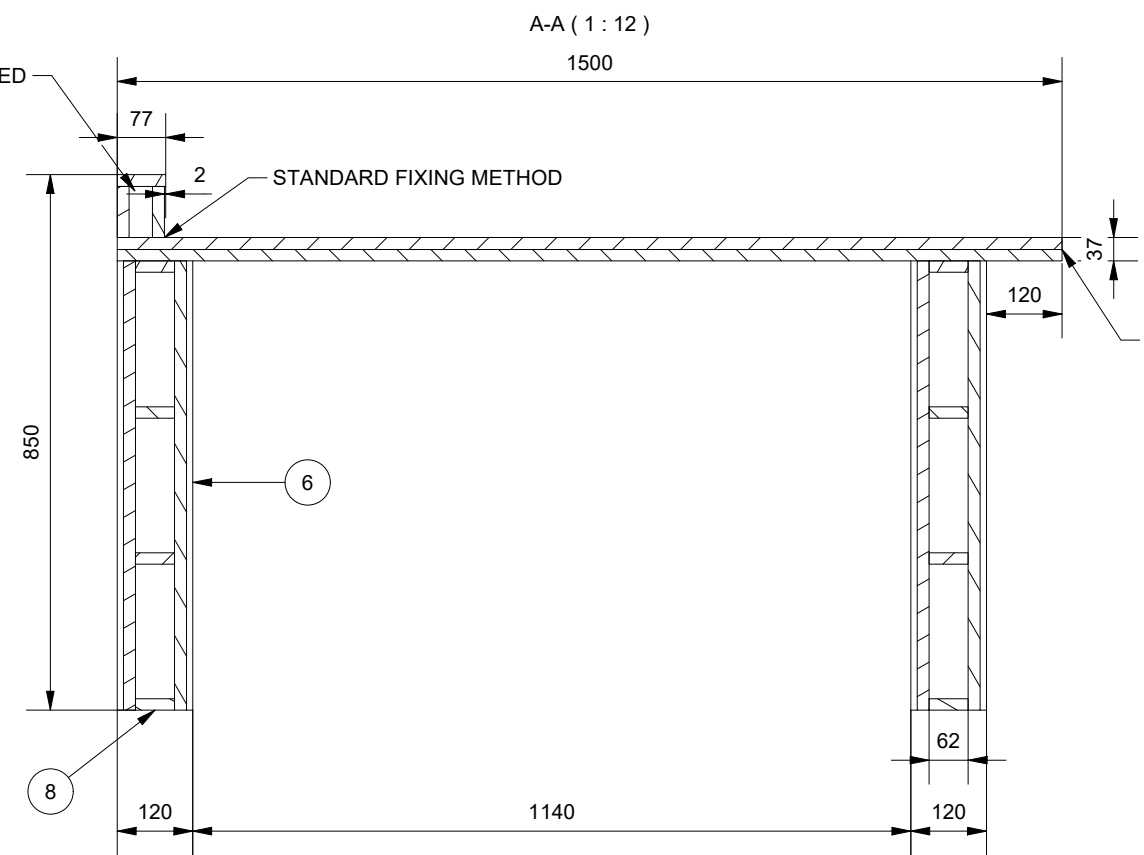
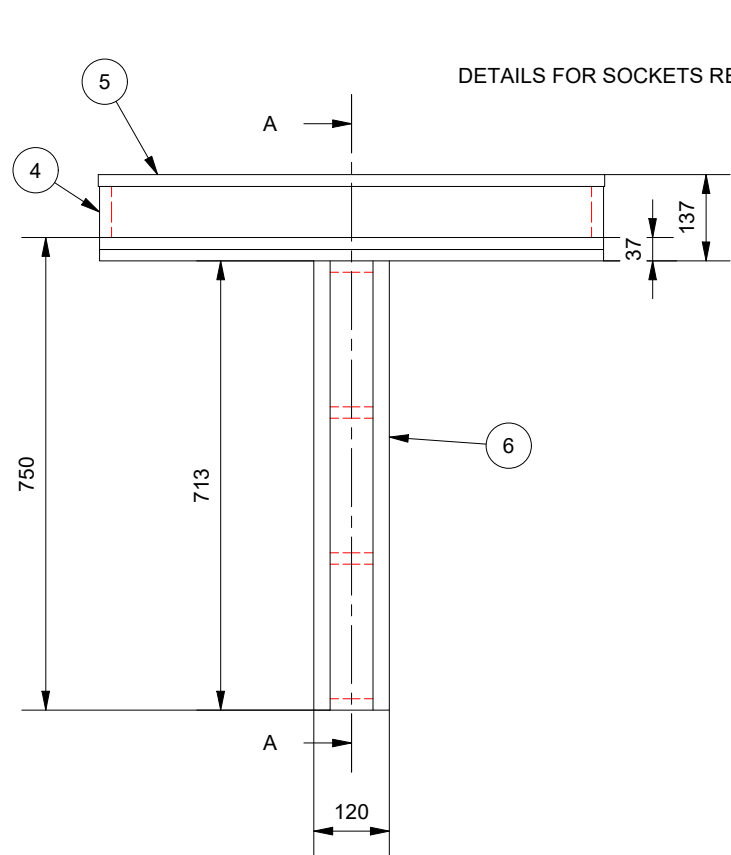

THICKNESS SET AS 37mm  
BASED ON 44mm HARDWOOD EDGING

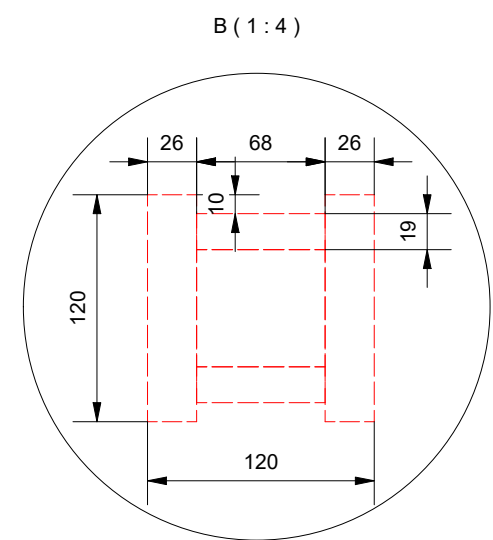
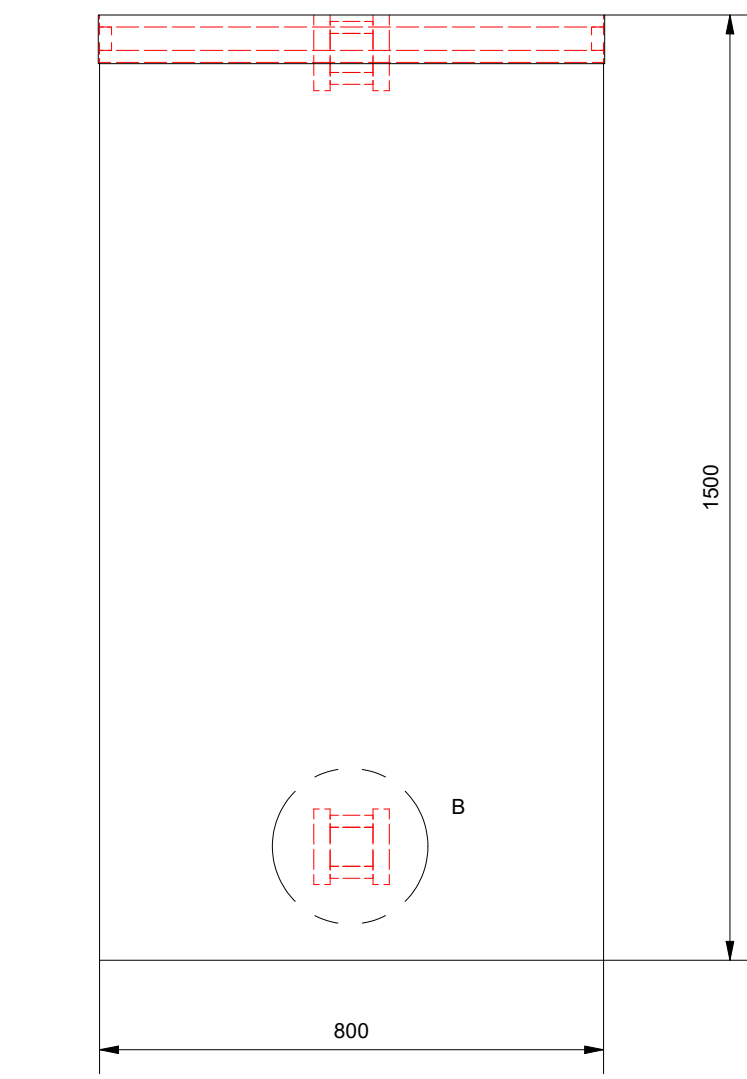

EDGED WITH 44m  
HARDWOOD OAK

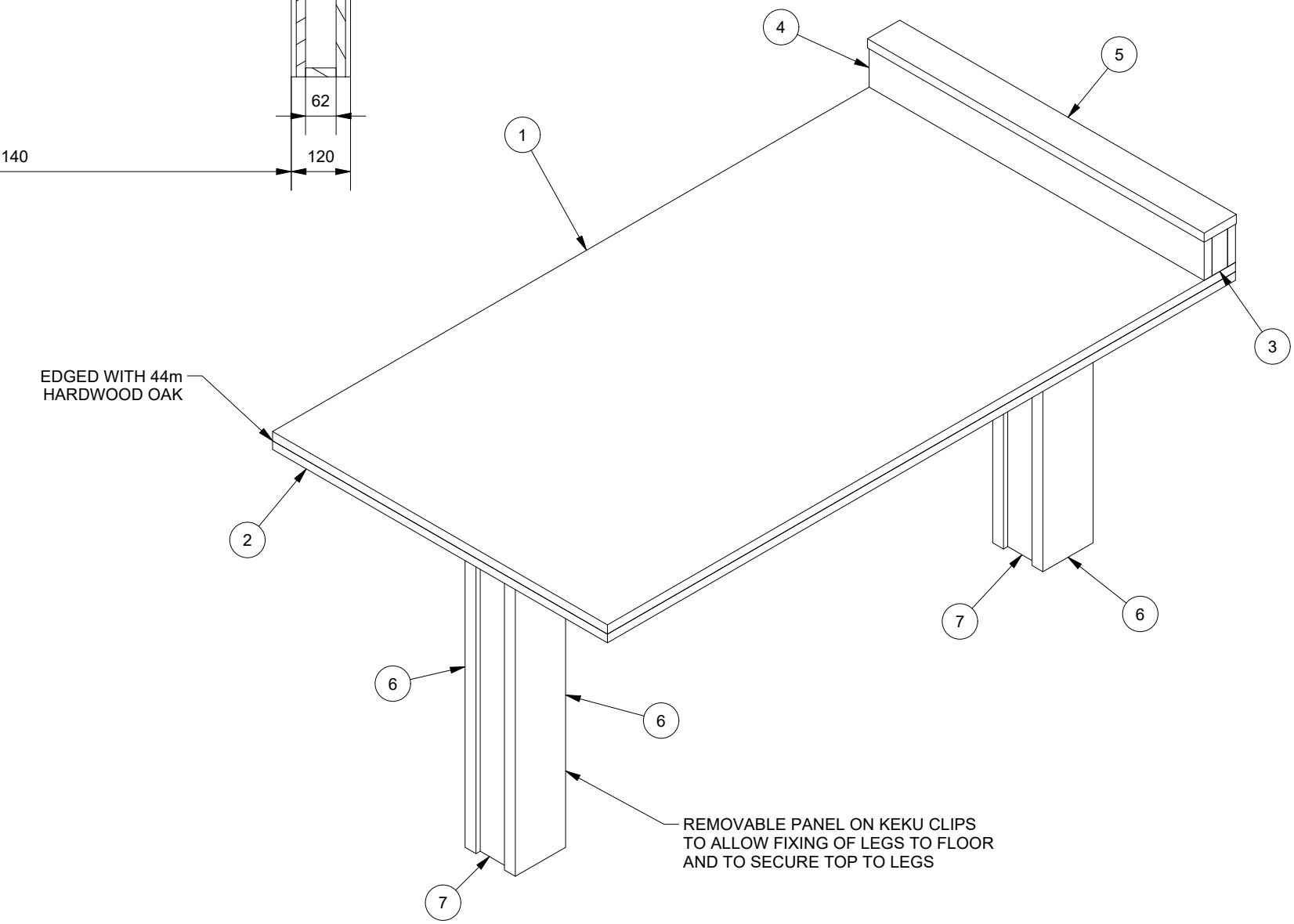

ALL VISIBLE EDGES TO BE EDGED IN HARDWOOD OAK

<b>FORMISIT</b>	FORMISIT LTD 11 KIRKSTEAD DRIVE DUNDEE, DD2 2FB www.formisit.com info@formisit.com	STATUS <b>FOR APPROVAL</b>	DRAWN Gavin	DATE 15/01/2021	TITLE <b>TABLE CAFE BOOTH SEATING</b>			
	THIS DOCUMENT IS CONFIDENTIAL AND IS SUPPLIED ON THE EXPRESS CONDITION THAT IT SHALL NOT BE COPIED, LENT, OR DISCLOSED TO ANY OTHER PERSON OR USED FOR ANY OTHER PURPOSE WITHOUT THE WRITTEN CONSENT OF FORMISIT LTD. <b>COPYRIGHT RESERVED</b>	DOCUMENT TYPE	CHECKED	APPROVED	DATE	DWG. No. <b>00027-001</b>	SHEET 1 OF 1	REV
		DIMENSIONS ARE IN mm <b>DO NOT SCALE</b>		THIRD ANGLE PROJECTION		MATERIAL: EST. MASS: 61.34 kg	SCALE: 1:10	SHEET: A3

ITEM	PART NUMBER	REV	DESCRIPTION	MATERIAL	QTY
1	00027-002-0100-01		19mm FRONT PANEL	OAK LAMINATE	1
2	00027-002-0101-01		19mm KICKER	OAK LAMINATE	1
3	00027-002-0102-01		19mm OPTIONAL END PANEL	OAK LAMINATE	2
4	00027-002-0103-01		19mm END PANEL	OAK LAMINATE	2
5	00027-002-0300-01		18mm UPRIGHT SUPPORT	MDF	5
6	00027-002-0301-01		18mm BACK RAIL	MDF	1
7	00027-002-0302-01		18mm BOTTOM RAIL	MDF	1
8	00027-002-0303-01		18mm FRONT RAIL	MDF	1
9	00027-002-0304-01		18mm TOP RAIL	MDF	1
10	00027-002-0305-01		18mm TOP RAIL	MDF	1
11	00027-002-0306-01		18mm MID RAIL	MDF	1
12	00027-002-0307-01		18mm SEAT BOARD	MDF	1
13	00027-002-0500-01		UPHOLSTERY	CAMIRA GRAVITY	1

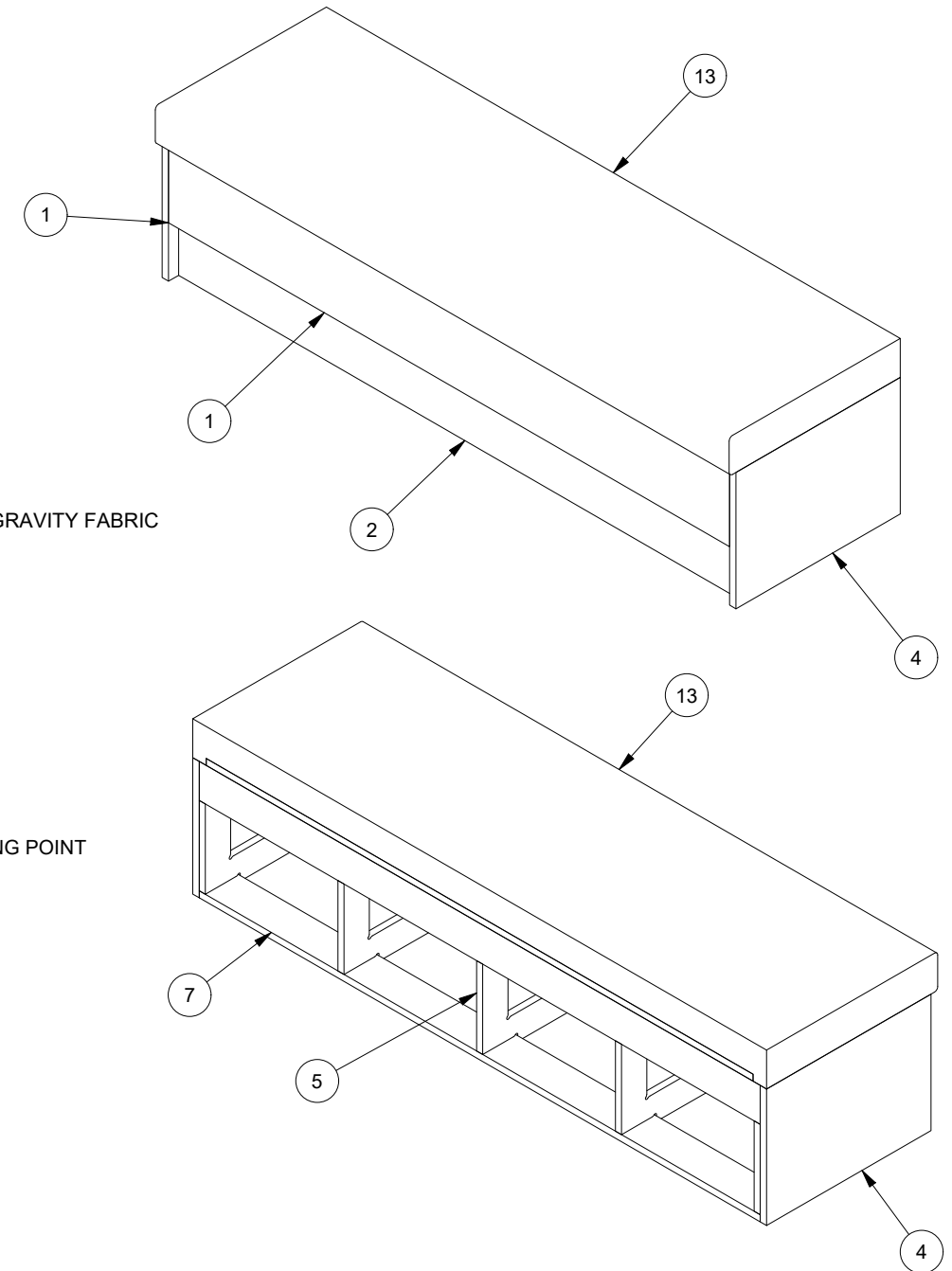
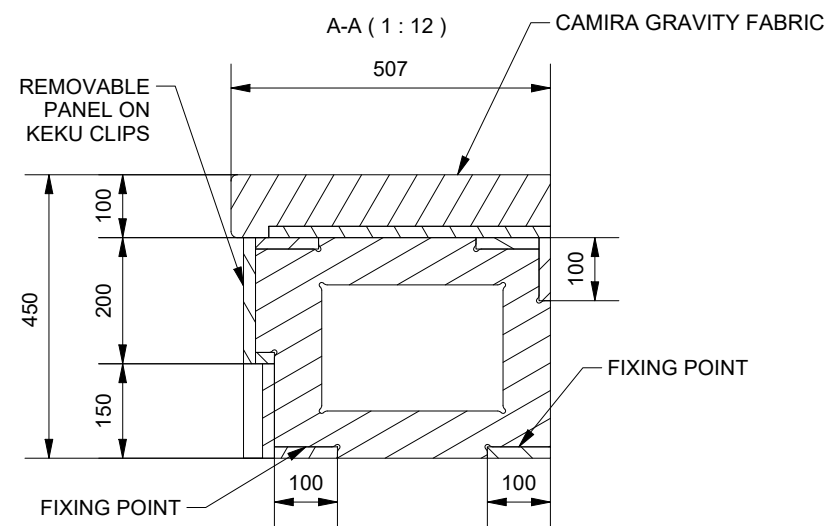
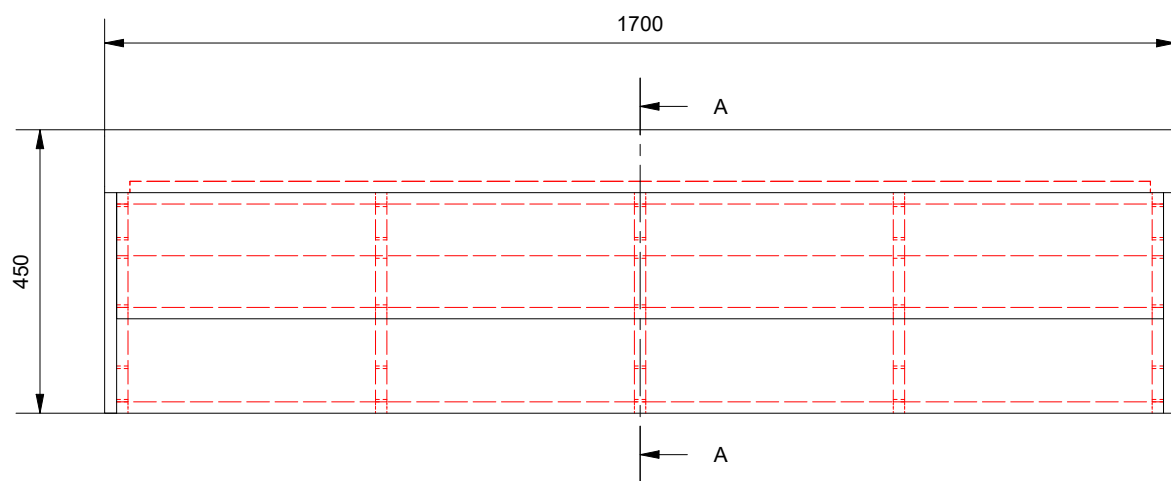
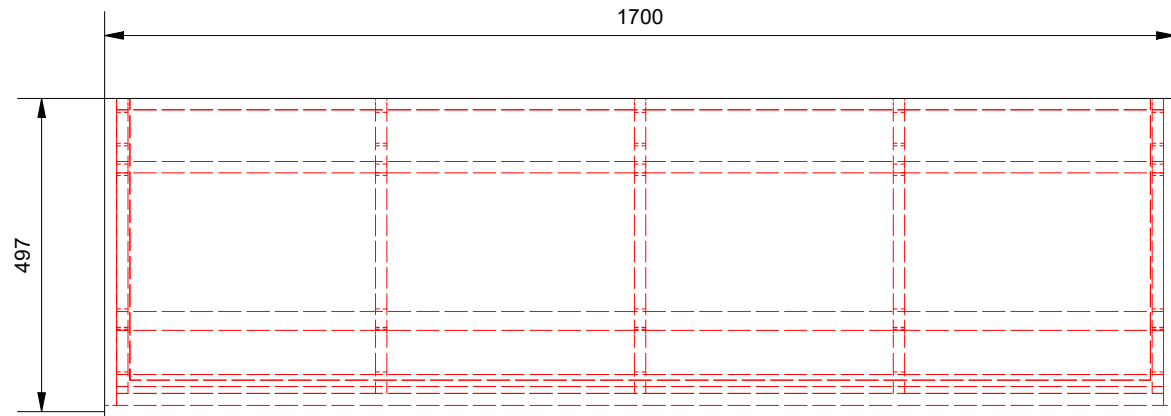

ALL VISIBLE EDGES TO BE EDGED IN HARDWOOD OAK

<b>FORMISIT</b>	FORMISIT LTD 11 KIRKSTEAD DRIVE DUNDEE, DD2 2FB www.formisit.com info@formisit.com	STATUS <b>FOR APPROVAL</b>	DRAWN Gavin	DATE 15/01/2021	TITLE <b>BENCH CAFE BOOTH SEATING</b>			
	THIS DOCUMENT IS CONFIDENTIAL AND IS SUPPLIED ON THE EXPRESS CONDITION THAT IT SHALL NOT BE COPIED, LENT, OR DISCLOSED TO ANY OTHER PERSON OR USED FOR ANY OTHER PURPOSE WITHOUT THE WRITTEN CONSENT OF FORMISIT LTD.  COPYRIGHT RESERVED	DOCUMENT TYPE	CHECKED	APPROVED	DATE	DWG. No. <b>00027-002</b>	SHEET 1 OF 1	REV
		DIMENSIONS ARE IN mm <b>DO NOT SCALE</b>	THIRD ANGLE PROJECTION			MATERIAL: EST. MASS: 134.98 kg	SCALE: 1:15	SHEET: A3