

Work space.

ESP STUDENT ACCOMMODATION CONCEPTS

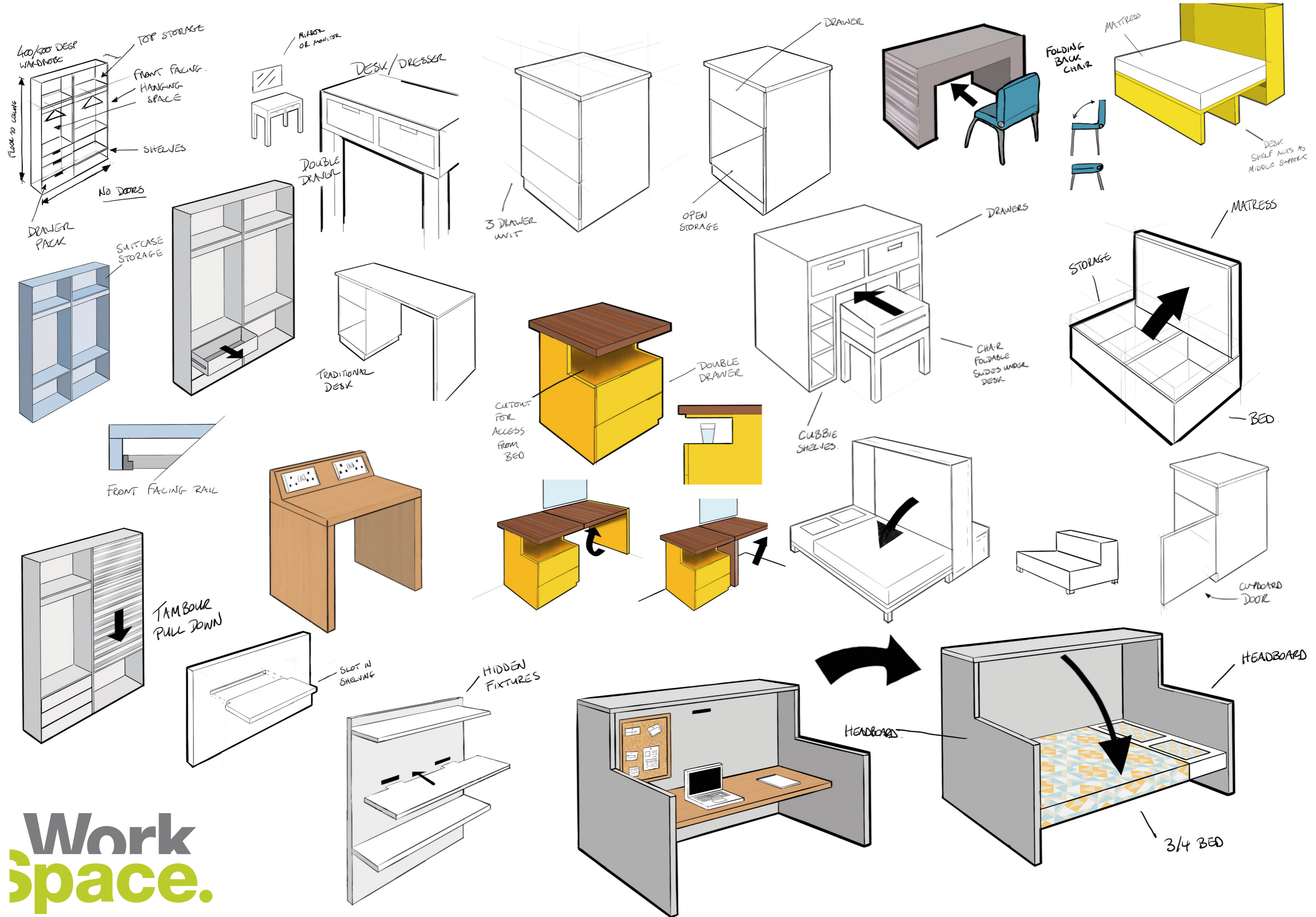

**Work
Space.**

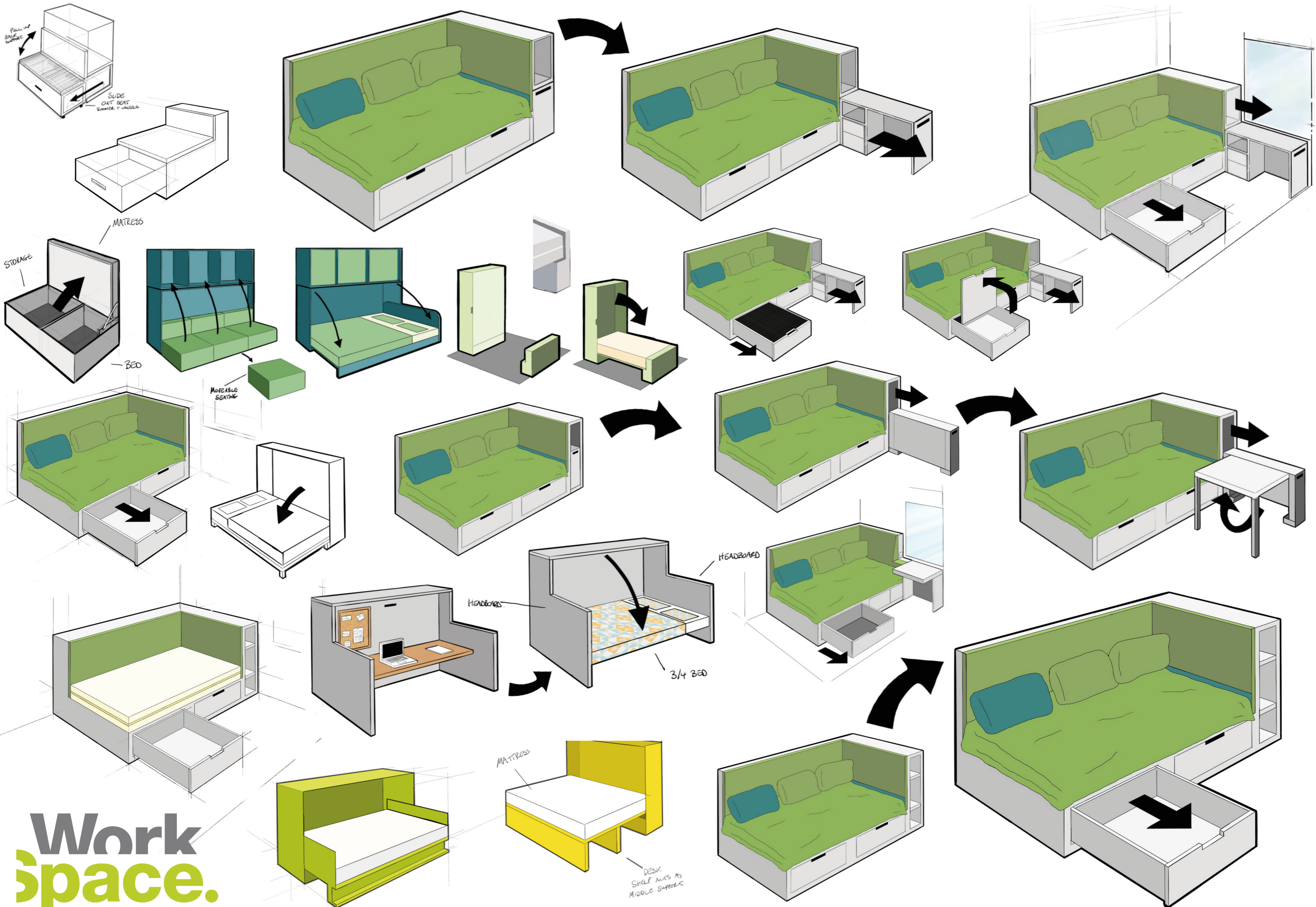

Work
Space.

LAYOUT A

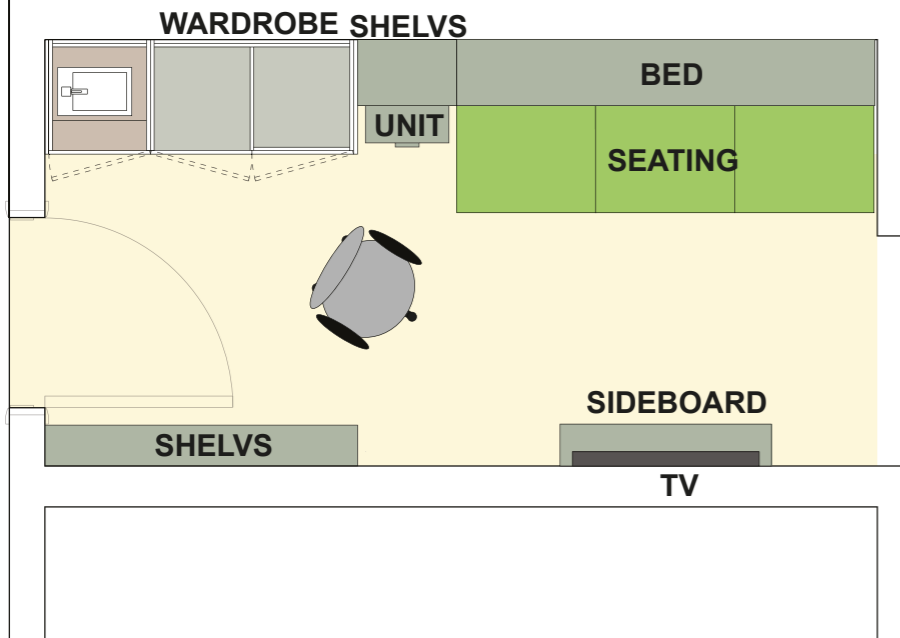

LIVING

WORKING

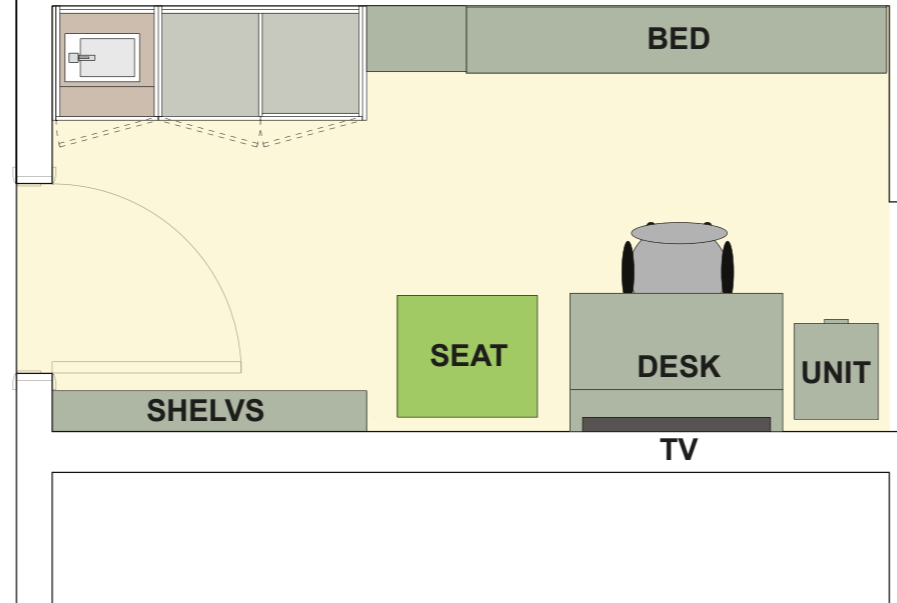

WORKING

SLEEPING

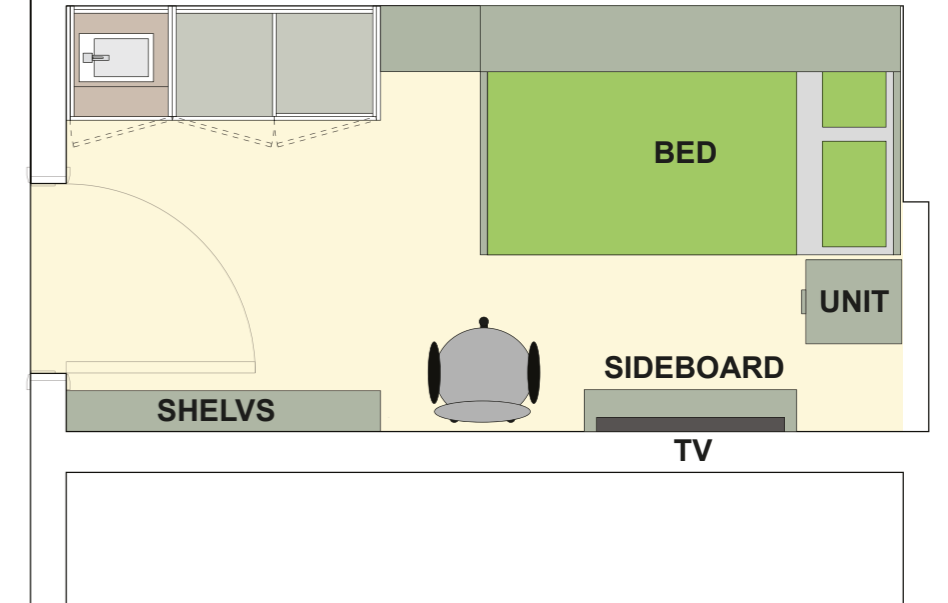

SLEEPING

WORKING

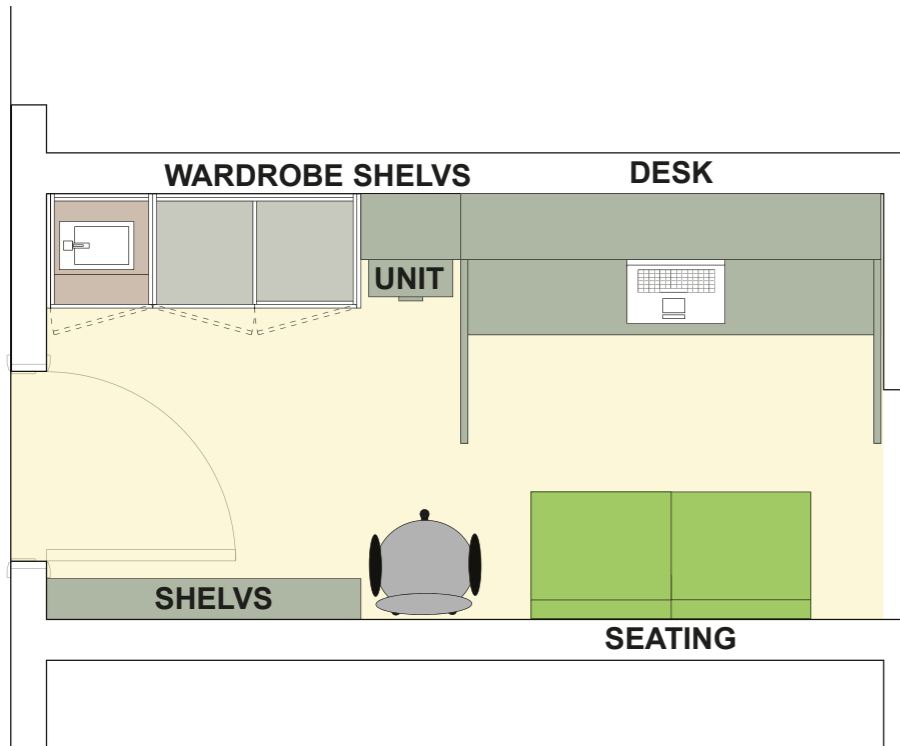

WORKING

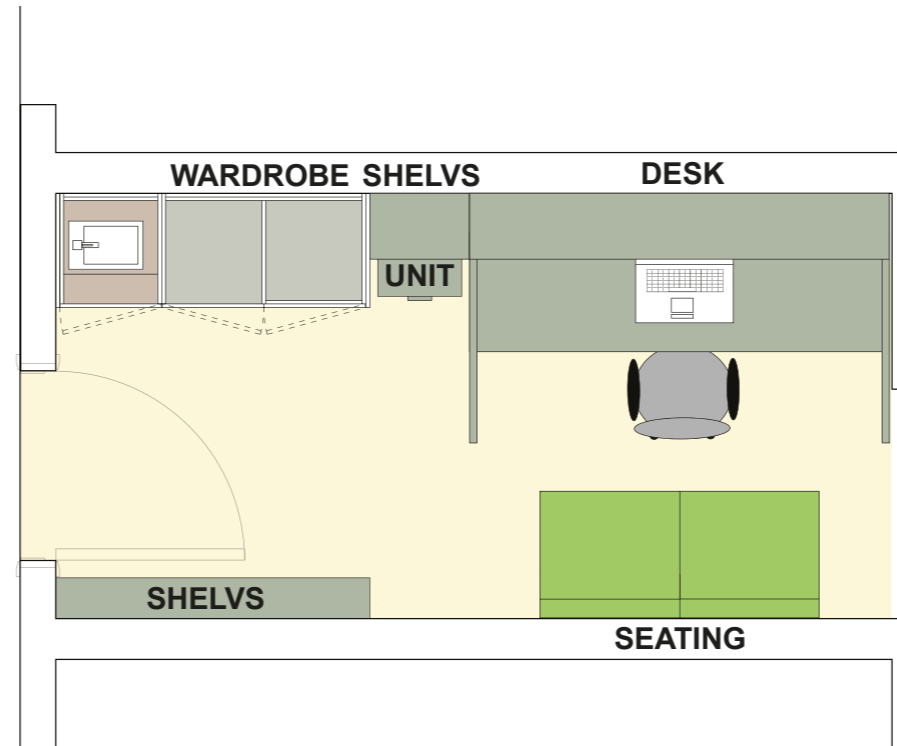

DESK

WORKING

SLEEPING

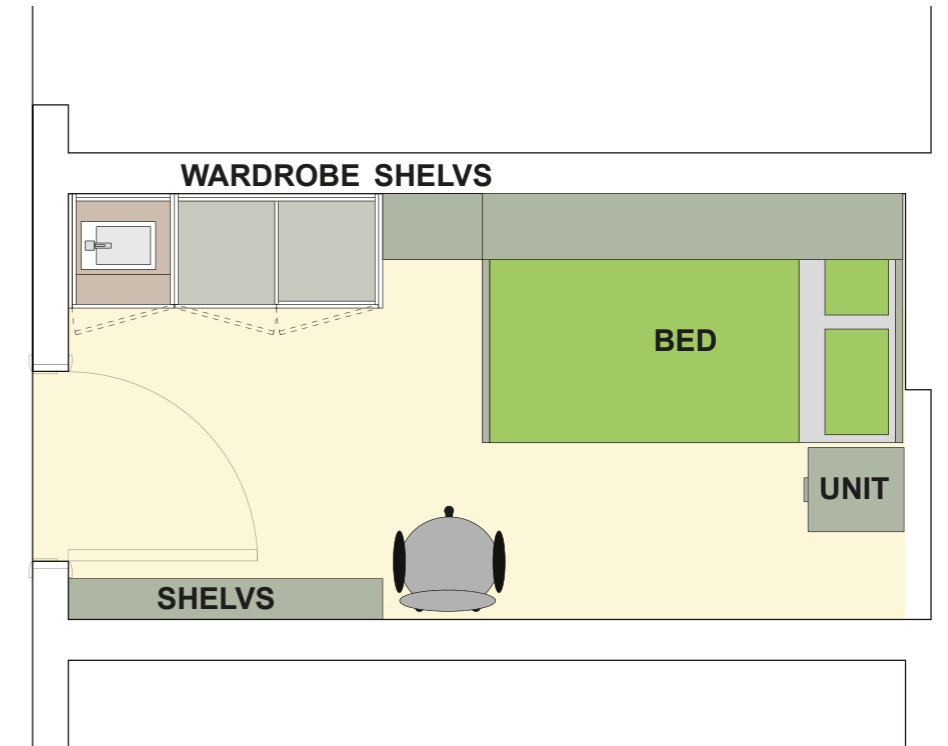

LAYOUT B

FOR CLIENT / CONTRACTOR
 PLEASE FILL IN THIS BOX PRIOR TO RETURN
 CLIENT REVIEW / APPROVAL: Initials..... Date.....
 STATUS A - NO COMMENTS, PROCEED.
 STATUS B - PROCEED WITH COMMENTS SHOWN.
 STATUS C - DO NOT PROCEED, COMMENTS SHOWN, RETURN FOR FURTHER APPROVAL.
 SITE SIZES MUST BE CONFIRMED PRIOR TO MANUFACTURE

PARTS LIST			
ITEM	QTY	PART NUMBER	DESCRIPTION
1	1	Walls	4100mm x 2085mm 2400mm
2	1	Vanity Unit	400mm x 400mm x 775mm
3	1	Wardrobe/Desk	1716mm x 400mm x 2018mm
4	1	Top Box 1000mm	1000mm x 400mm x 350mm
5	1	Top Box 400mm	400mm x 400mm x 350mm
6	1	Vanity Top Unit	400mm x 400mm x 500mm
7	1	Pull Down Desk Bed	1957mm x 1521mm x 1578mm
8	1	Shelves	4100mm x 218mm x 2400mm
9	1	Bedside Cabinet	500mm x 500mm x 700mm

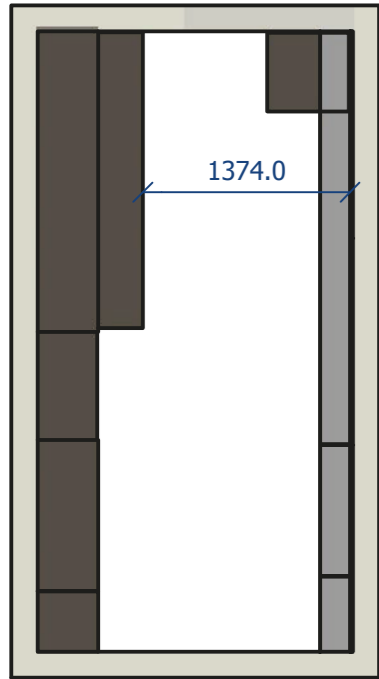
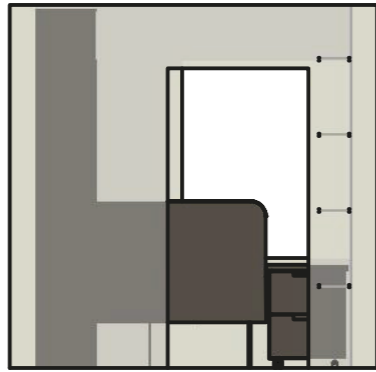
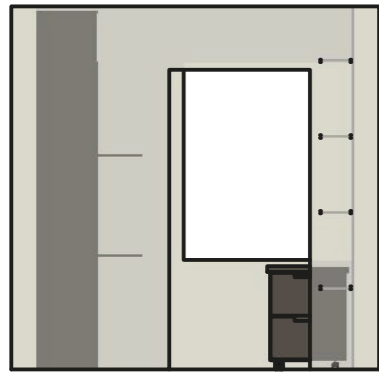

DESK MODE

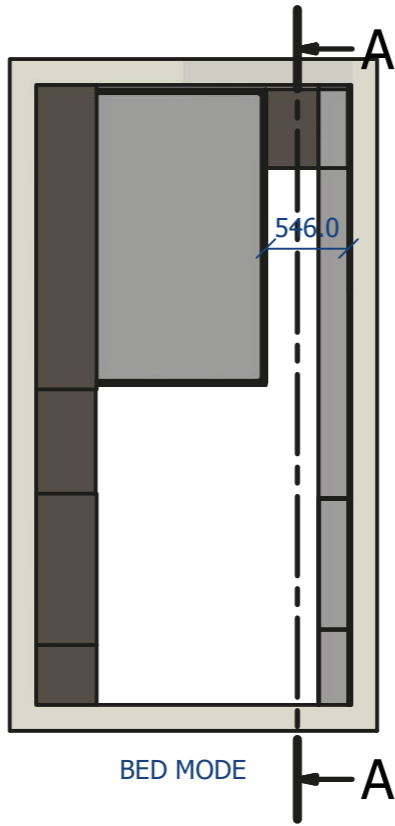

BED MODE

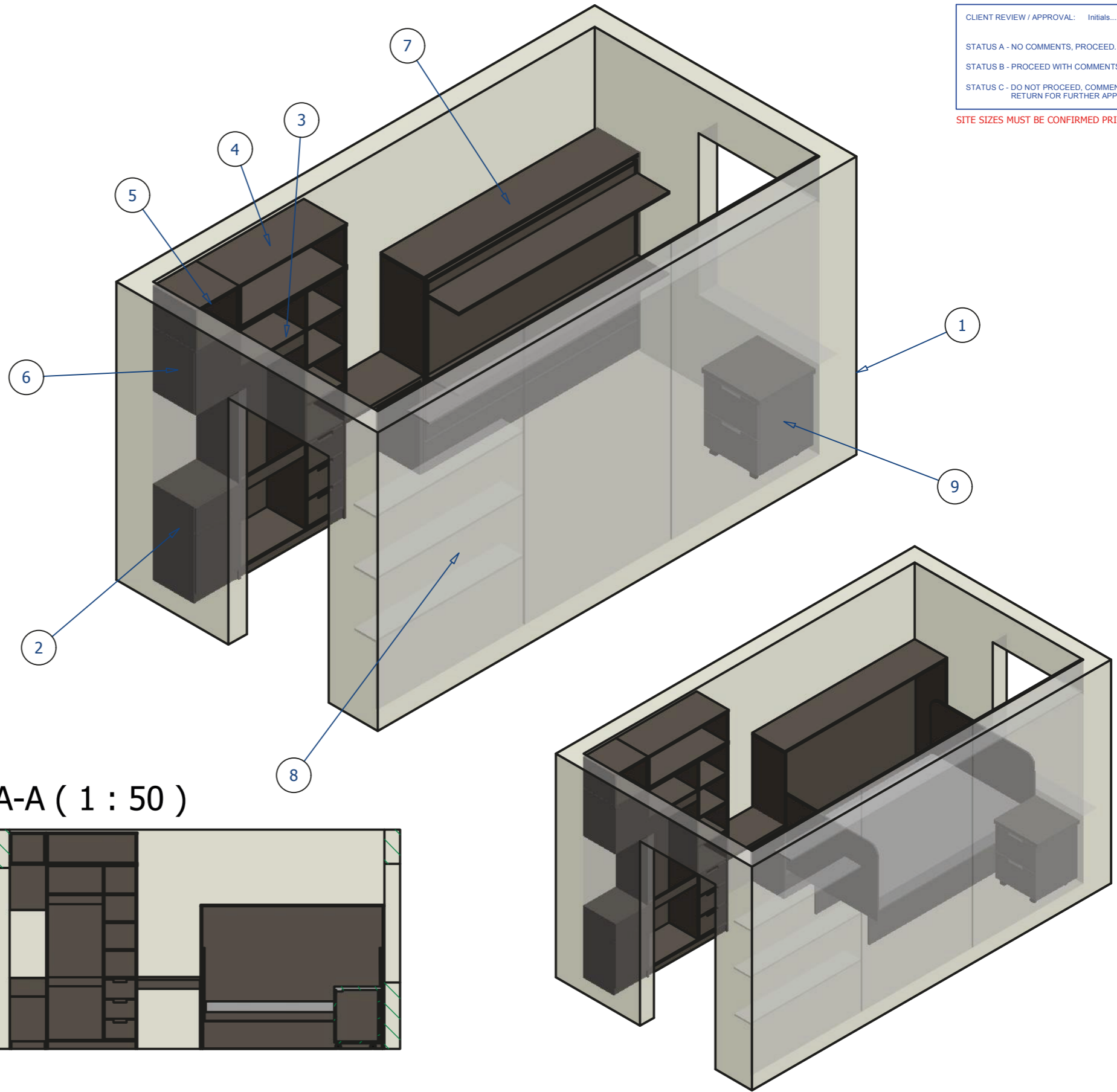

A-A (1 : 50)

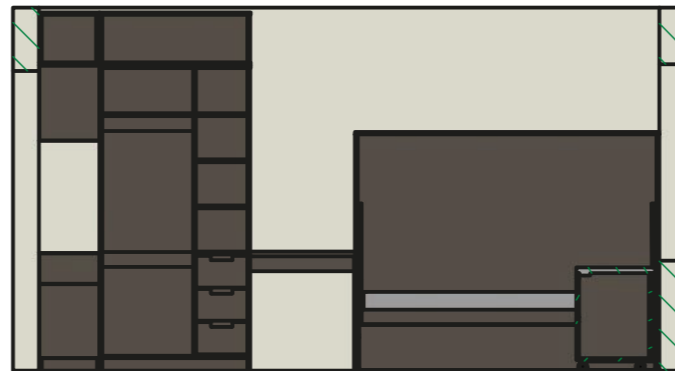

Client
 Empiric Student Property

Project
 Student Accomodation Concepts ESP - Concept Room

Drawing
 Sheet 1 / 2

Project No.
 ESP - Concept Room

Drawing No.
 ESP-Concepts-A

Status
 For Approval

Material
 TBC

File Path
 C:\C-Drive Projects\Empiric Student Property - Concepts

Qty
 N/A

Created • Gavin Birmingham
 Date • 5/31/2017
 Checked •

01738 633184

weareworkspace.com
 1 Bertha Park View - Perth - PH1 3JE

- STATUS A - NO COMMENTS, PROCEED.
- STATUS B - PROCEED WITH COMMENTS SHOWN.
- STATUS C - DO NOT PROCEED, COMMENTS SHOWN, RETURN FOR FURTHER APPROVAL.

SITE SIZES MUST BE CONFIRMED PRIOR TO MANUFACTURE

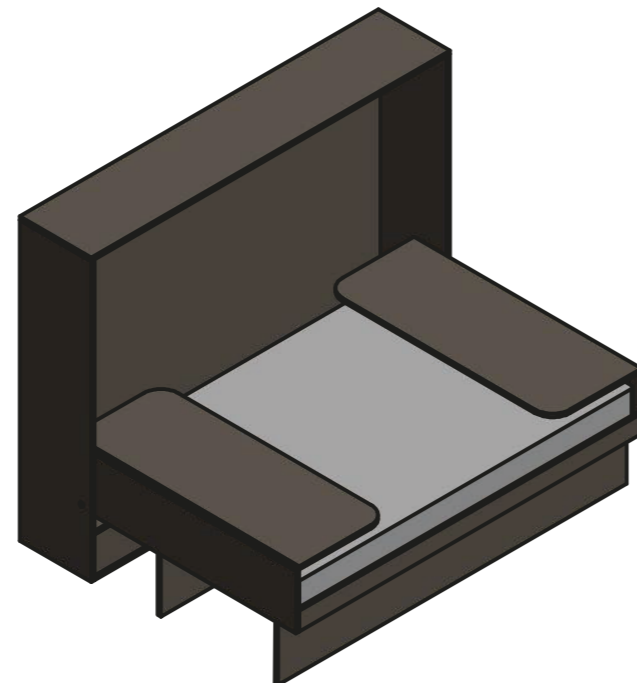
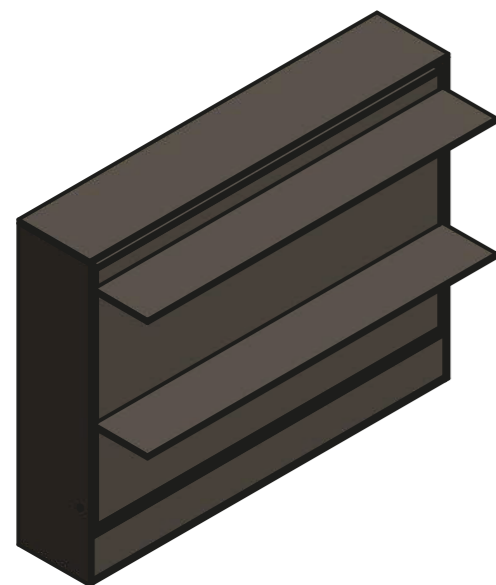
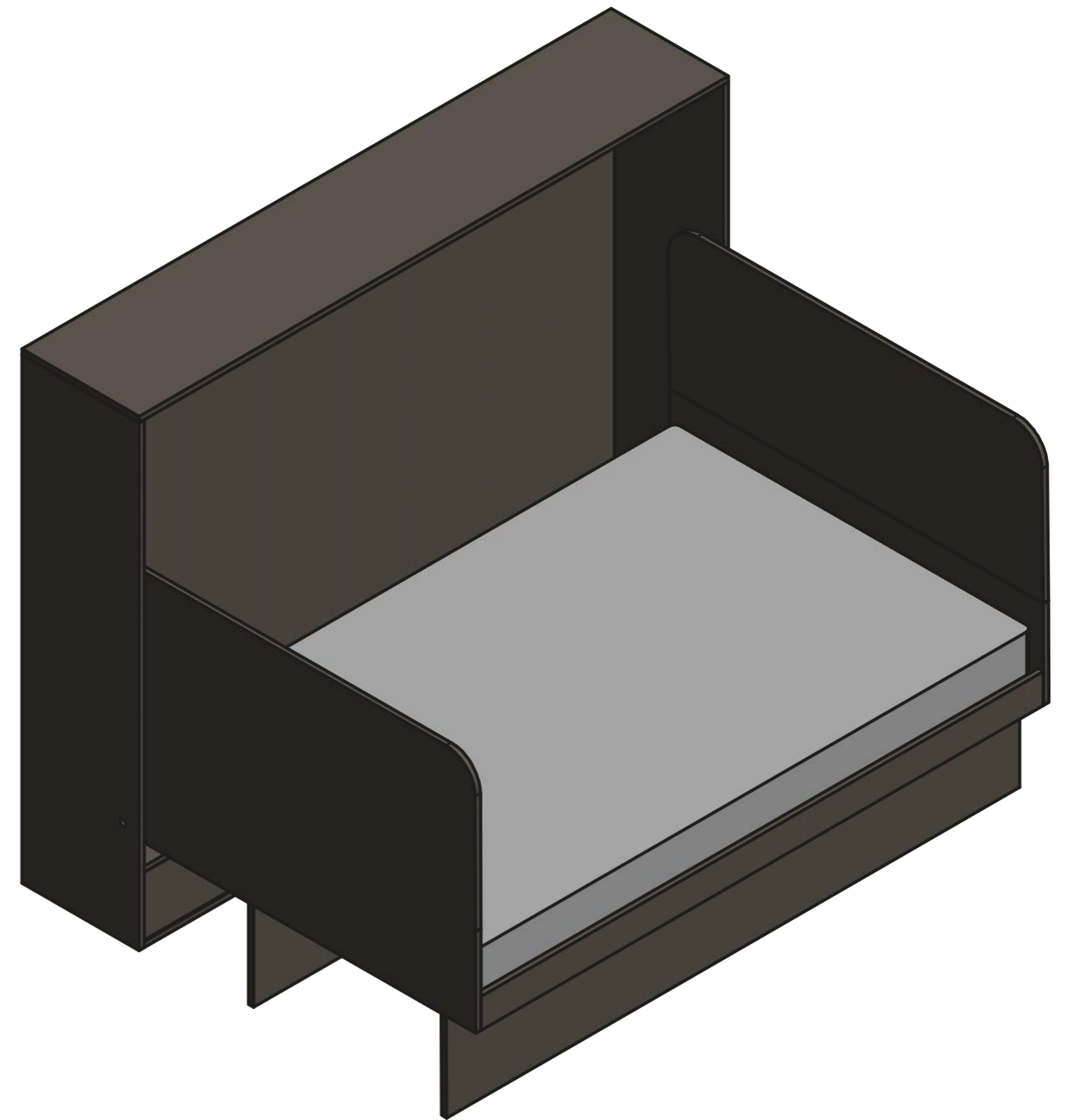
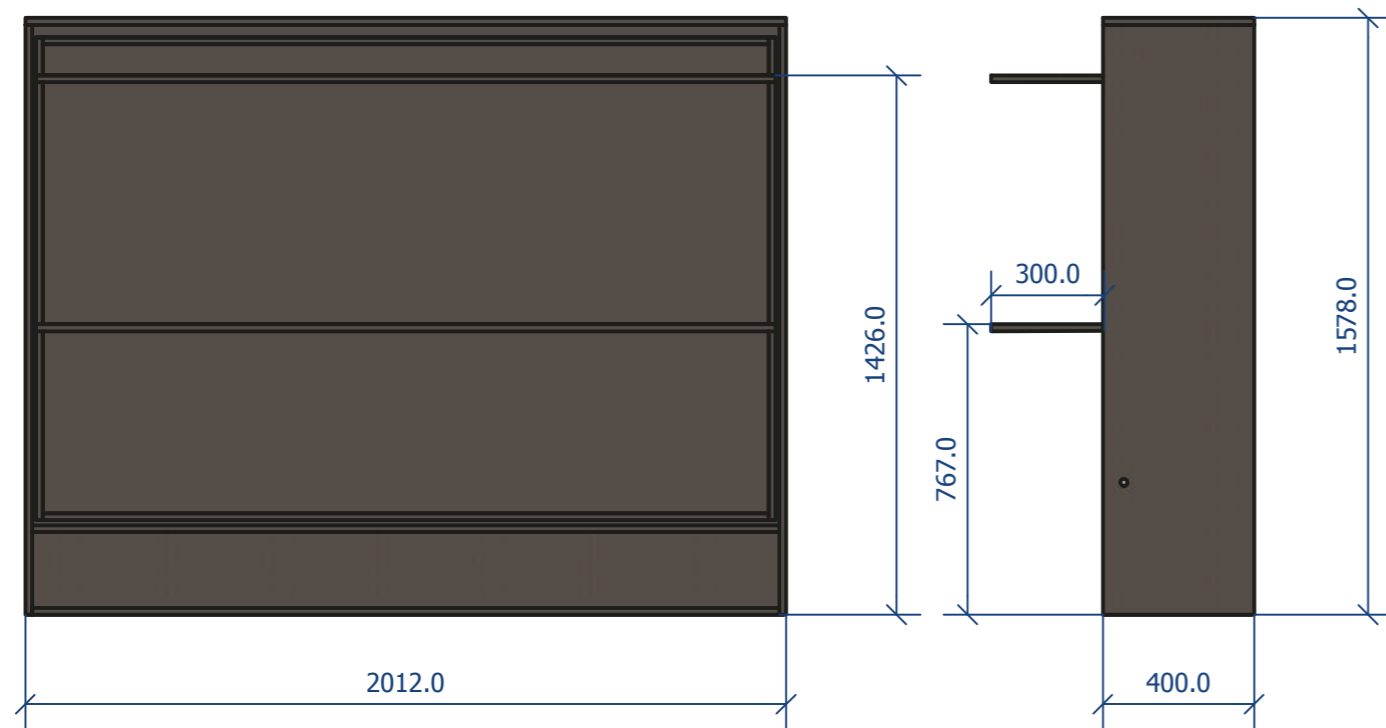

Desk Mode

Pull Down Bed

Lift up headboards

Bed Mode

PARTS LIST			
ITEM	QTY	PART NUMBER	DESCRIPTION
1	1	Walls	4100mm x 2085mm 2400mm
2	1	Vanity Unit	400mm x 400mm x 775mm
3	1	Shelves	4100mm x 218mm x 2400mm
4	1	Wardrobe/Desk	1716mm x 400mm x 2018mm
5	1	Top Box 1000mm	1000mm x 400mm x 350mm
6	1	Day Bed	1988mm x 1288mm x 650mm
7	1	Top Box 400mm	400mm x 400mm x 350mm
8	1	Vanity Top Unit	400mm x 400mm x 500mm
9	1	Bedside Cabinet	500mm x 500mm x 700mm

FOR CLIENT / CONTRACTOR
PLEASE FILL IN THIS BOX PRIOR TO RETURN

CLIENT REVIEW / APPROVAL: Initials..... Date.....

STATUS A - NO COMMENTS, PROCEED.

STATUS B - PROCEED WITH COMMENTS SHOWN.

STATUS C - DO NOT PROCEED, COMMENTS SHOWN, RETURN FOR FURTHER APPROVAL.

SITE SIZES MUST BE CONFIRMED PRIOR TO MANUFACTURE

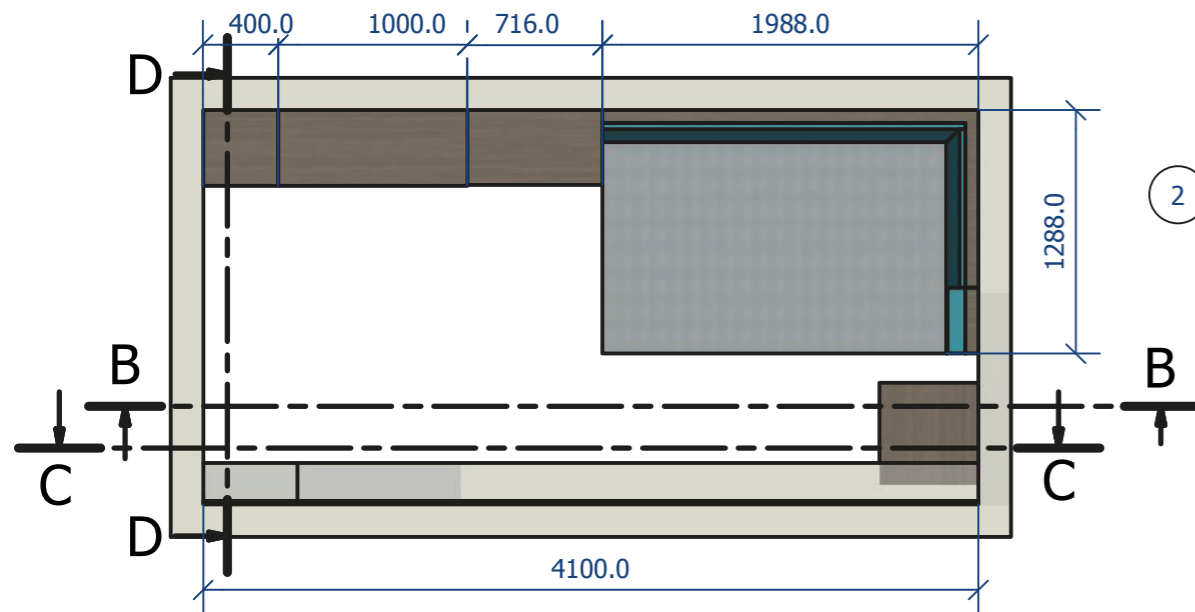

B-B (1 :40)

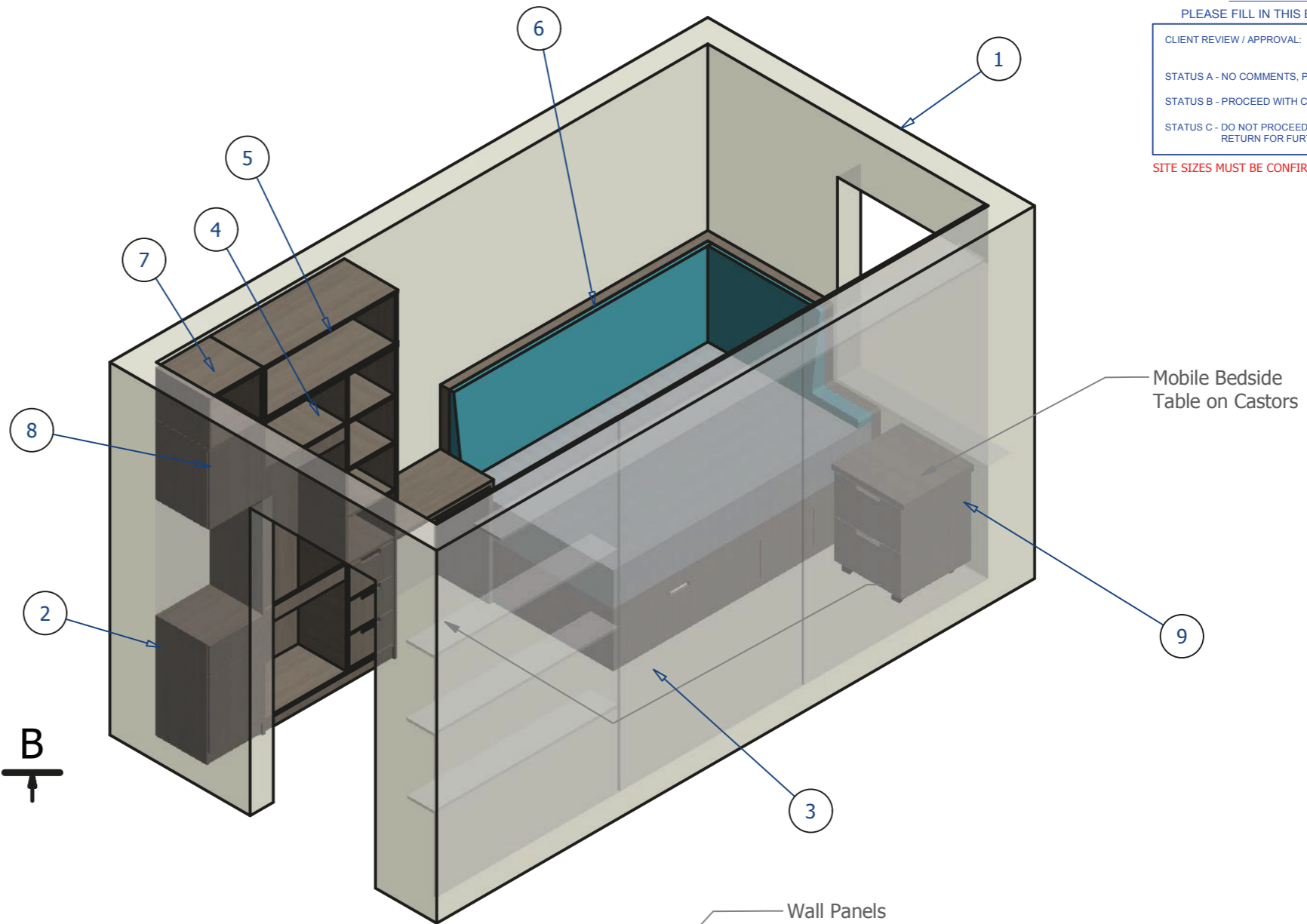

C-C (1 :40)

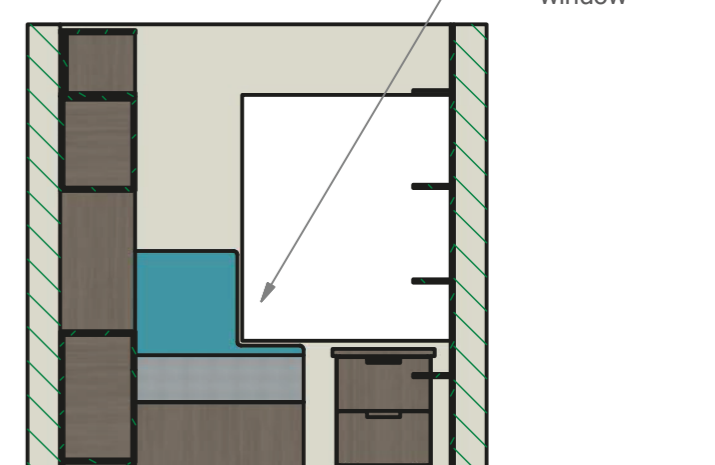
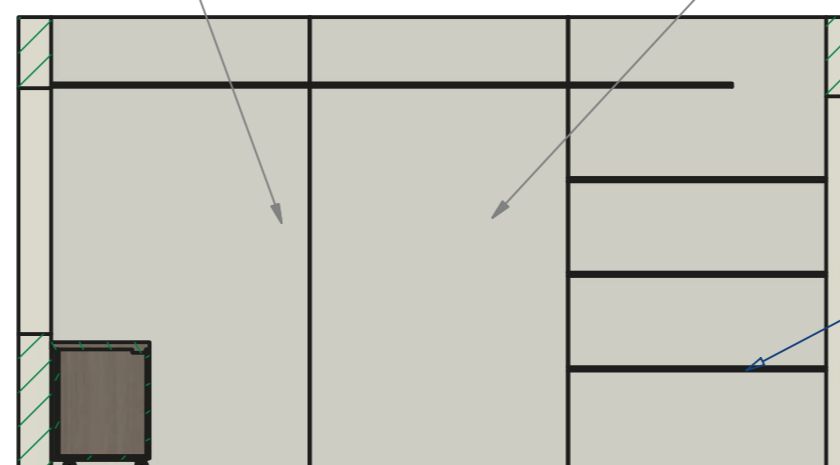

Under Bed Storage



Client
Empiric Student Property

Project
Student Accomodation Concepts

Drawing
Sheet 1 /2

Project No.
ESP - Concept Room

Drawing No.
ESP-Concepts-B

Status
For Approval

Material
TBC

File Path
C:\C-Drive Projects\Empiric Student Property - Concepts

Qty
N/A

Created • Gavin Birmingham
Date • 5/31/2017
Checked •

01738 633184

weareworkspace.com
1 Bertha Park View - Perth - PH1 3JE

CLIENT REVIEW / APPROVAL: Initials..... Date.....

- STATUS A - NO COMMENTS, PROCEED.
- STATUS B - PROCEED WITH COMMENTS SHOWN.
- STATUS C - DO NOT PROCEED, COMMENTS SHOWN, RETURN FOR FURTHER APPROVAL

SITE SIZES MUST BE CONFIRMED PRIOR TO MANUFACTURE

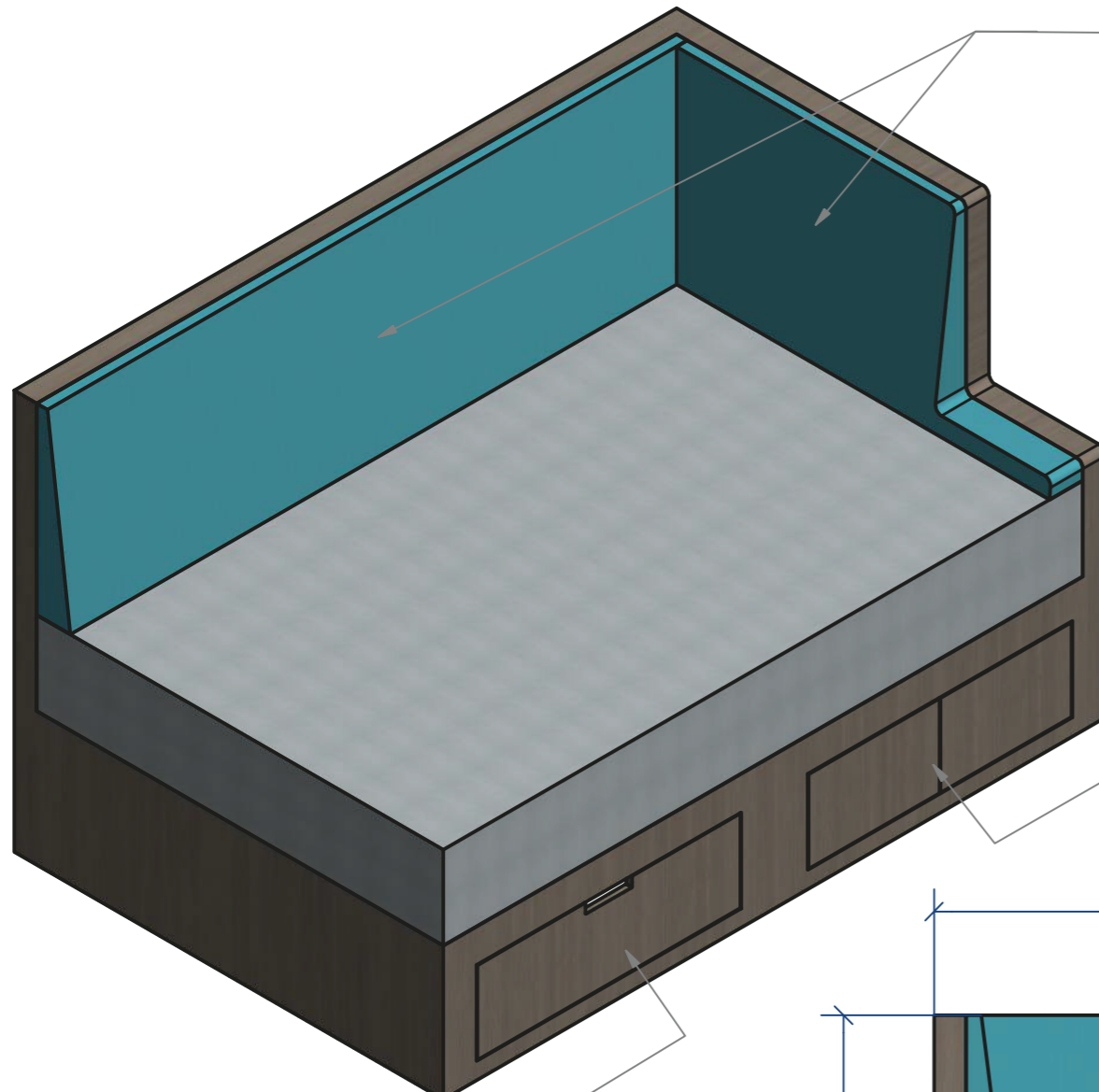

Drawer Storage

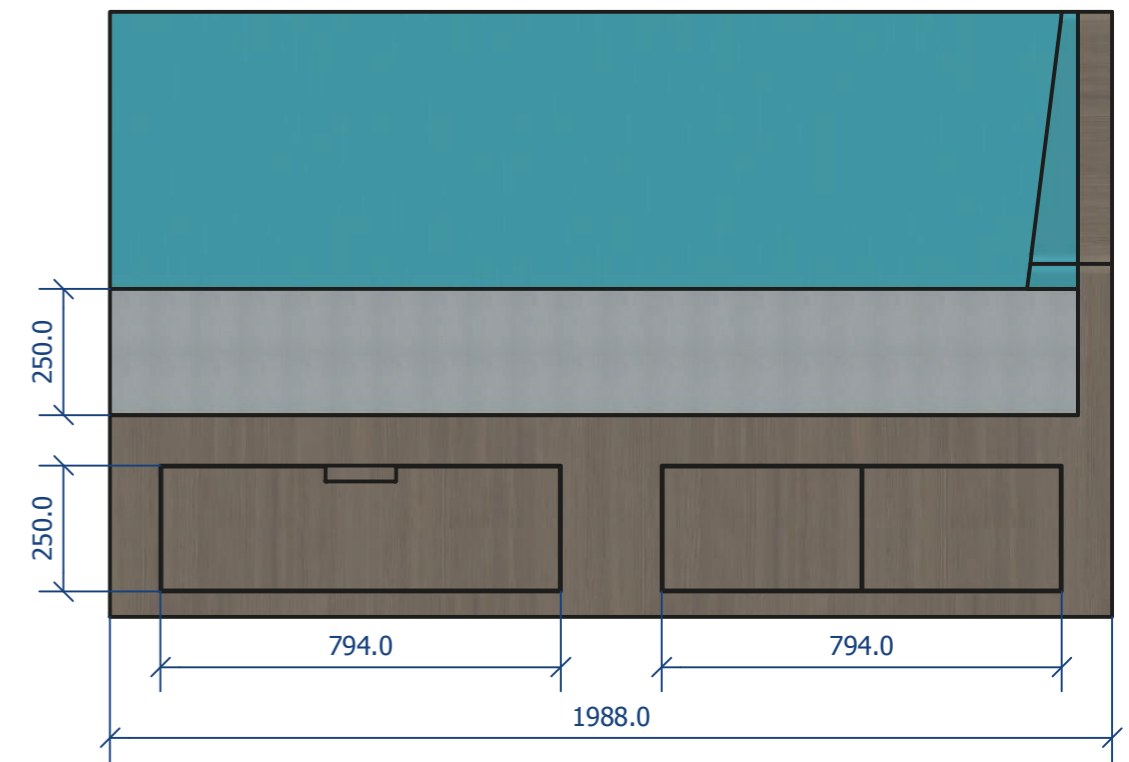
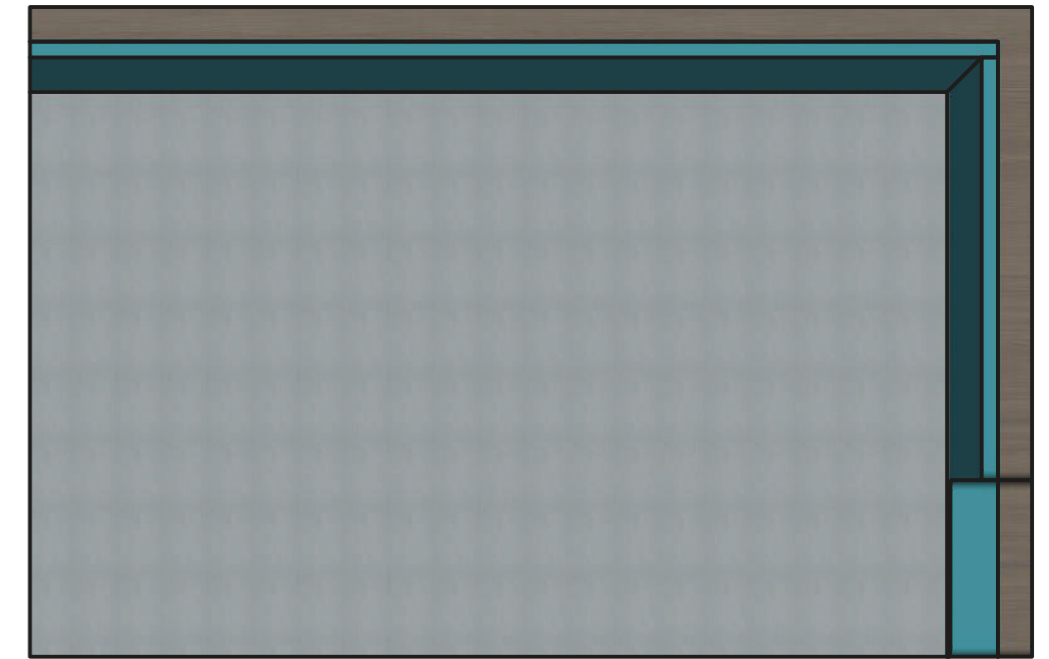
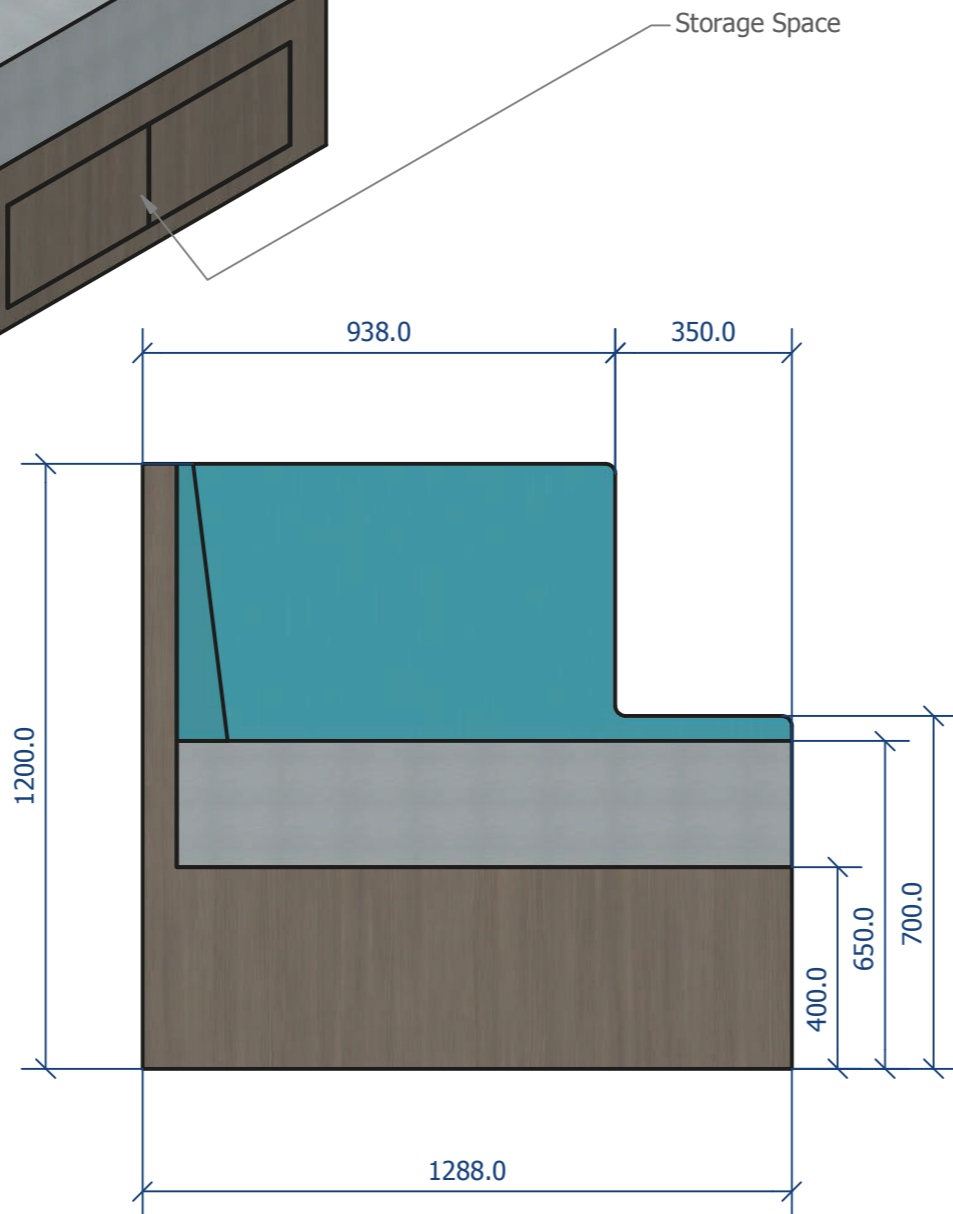

Client
Empiric Student Property

Project
Student Accomodation Concepts

Drawing
Sheet 2 / 2

Project No.
ESP - Concept Room

Drawing No.
ESP-Concepts-B

Status
For Approval

Material
TBC

File Path
C:\C-Drive Projects\Empiric Student Property - Concepts

Qty
N/A

Created • Gavin Birmingham
Date • 5/31/2017
Checked •

01738 633184